

Data Sheet AO-03

Oxygen Sensor

- Linear output from 1 to 25% Vol.
- No external power supply
- Plug-and-play
- Quick response
- Accurate and reliable

Product Summary

The AO-03 oxygen sensor is an electrochemical sensor for oxygen concentration detection. It adopts a molded body design, and has the advantages of fast response and reliability. The AO-03 oxygen sensor is compact, easy to carry and install, and it is more cost-effective than similar sensors.

1 Product Description

AO-03 oxygen sensor is widely used in the fields of mining, steel manufacturing, petrochemical and air monitoring. For example, it can be integrated into oxygen alarms in mines, air quality detectors and commercial air purification equipment. The data provided in this document are valid at 20°C, 50% RH and 1013 mbar for 3 months after the manufactured date of sensor. Please strictly follow the instructions for operating the oxygen analyzer and replacing the oxygen sensor.



Figure 1. AO-03 Oxygen Sensor

2 Sensor Specifications

2.1 Technical Specifications

Table 1. Sensor Technical Specifications

Measurement ¹	
Operating Principle	Electrochemical
Output Signal	0.1 ± 0.03 mA in Air
Measurement Range	1 – 25% Vol. O ₂
Response Time (T ₉₀)	<15 s
Baseline Offset	<0.6% Vol. O ₂
Linearity	Linear 1-25% Vol. O ₂
Electrical	
Recommended Load Resistor	100 Ω
Mechanical	
Housing Material	ABS
Weight	<16 g
Orientation	<0.2% Vol. O ₂ equivalent
Environmental	
Operating Temperature Range	0 to 50 °C
Recommended Storage Temp	0 to 20 °C
Operating Pressure Range	Atmospheric ± 20%
Operating Humidity Range	5 – 99% RH non-condensing
Lifetime	
Long Term Output Drift	< 2% signal/month
Expected Operating Life	2 years in Air
Packaging	Sealed blister

¹Specifications are valid at 20°C, 50% RH and 1013 mbar. Performance characteristics outline the performance of sensors supplied within the first 3 months.

²Output signal can drift below the lower limit over time.

2.2 Product Dimensions (unit: mm)

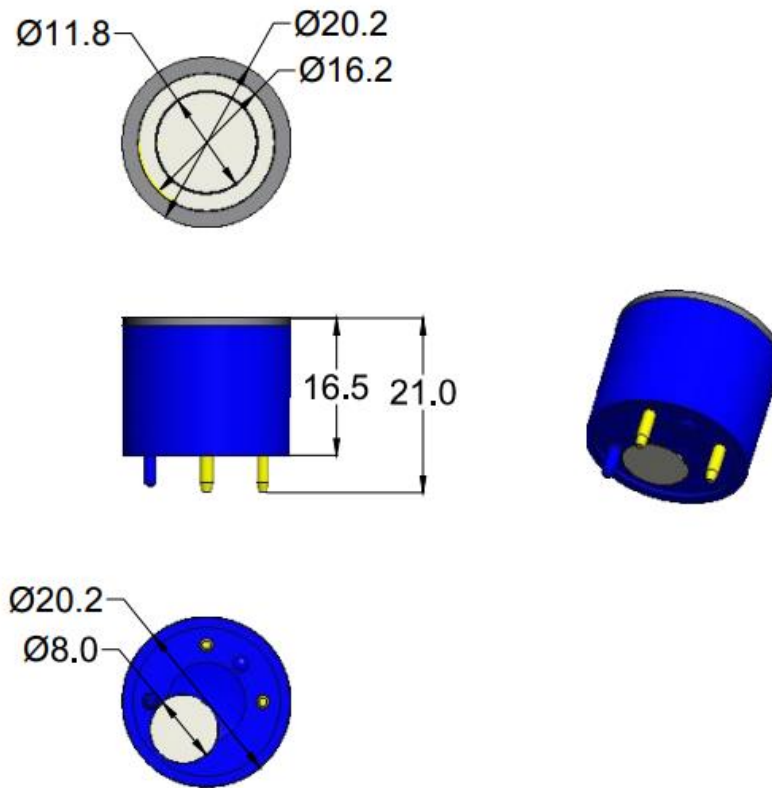

Figure 2. AO-03 Dimensions

3 Installation and Use

3.1 Storage and Use

AO-03 is designed to operate in various environments and harsh conditions, but it is still necessary to avoid exposing to high concentrations of solvent vapor during storage, installation and operation.

When using a sensor with a printed circuit board (PCB), use a degreaser before installing the sensor. Do not paste directly on or near the case, as the solvent may cause cracking of plastic.

3.2 Cross Sensitivity Table

Toxic gases at TLV levels will have no cross-sensitivity effect on sensors. At very high levels (i.e. percent levels), highly oxidising gases (e.g. ozone, chlorine) will interfere to the extent of their oxygen equivalent, but most other commonly occurring gases will have no effect.

3.3 Acid Gases

Acid gases such as CO₂ and SO₂ will be absorbed by the electrolyte and tend to increase the flux of oxygen to the electrode. This gives an increased oxygen signal of approximately 0.3% of signal per 1% CO₂. Oxygen sensors are not suitable for continuous operation in concentrations of CO₂ above 25%.

4 Safety Note

- In order to ensure the normal operation of the sensor and the instrument that employs the sensor, it is required to confirm the performance of the equipment in the target gas (blow check) before each use of the sensor and/or. Failing to perform such tests may endanger personal and property safety.
- Please read the data sheet and product manual carefully, failing to follow these instructions may result in death or serious injury.
- In no event shall Aosong Electronics be liable for consequential, special, or indirect damages.